

ExCam[®] IPP1488

User Manual



Table of contents

1	Introduction	4
2	Technical data	4
2.1	Explosion protection	4
2.2	Illustration of the model key.....	5
2.3	Electrical parameters of the camera.....	7
2.4	Cables and glands.....	7
2.4.1	Connection cable for devices with flipConnect®	7
2.4.2	Connection cable Ex-d – Ex-e	7
2.4.3	Cable glands PoE and protection hose	8
2.5	Video-technical characteristics	8
2.6	Other technical data	9
3	Safety Instructions	9
4	Installation	10
5	Electrical connection	13
5.1	Potential equalization	13
5.2	Connection work at the device and fuses.....	14
5.2.1	Connection work at the device via flipConnect®	14
5.2.2	Connection work at the device without flipConnect®	17
5.2.3	Appropriate cables & cable entries.....	21
5.2.4	Plug assignments (RJ45).....	22
5.2.5	Tests prior to switching on voltage	23
6	Working inside the housings (Ex-d)	24
6.1	Preparation for work:	24
6.2	Opening the camera housing	24
6.3	Removing / inserting a SD memory card	26
6.4	Hardware Reset	26
6.5	Closing of the pressure-resistant housing	27
7	Network access and visualization	28
7.1	Browser Support.....	28
7.2	Assigning the IP address.....	28
7.3	Password/ Identification	29
8	Maintenance / Modification.....	30
8.1	Repair and correction	30
9	Disposal / Recycling	30
10	Drawings, 3D models, certificates and further documentation.....	30

Table of Figures and Charts

Table 2-1 Model key	5
Figure 2-1 Sectional view of SKD02-T	7
Figure 2-2 Sectional view of ASKD02-T	8
Table 2-2 Other technical data	9
Table 4-1 Mounting accessories.....	12
Figure 5-1 ExCam IPP1488 potential equalization (similar illustration)	13
Table 5-1 Potential equalization	14
Figure 5-2 Connection via flipConnect®	14
Figure 5-3 Cable gland (KLE) and supply line	17
Figure 5-4 ExCam IPP1488 T08-VA2.1.KX.BOR-L.H-xxx.X- T (similar illustration)	17
Figure 5-5. ExCam IPP1488 T08-VA2.1.K1.BOR-L.H-005.X- P (similar illustration).....	18
Figure 5-6 Video Tutorial ExTB-3	18
Tab. 5-2. Wire assignment of terminal box ExTB-2 (SKD02-T)	19
Tab. 5-3 Wire assignment of terminal box ExTB-2 (ASKD02-T).....	19
Figure 5-7 Sample circuit of terminal box ExTB-2	20
Figure 5-8 Photo of the wired terminal box ExTB-2	20
Figure 5-9 Ex-d cable selection	22
Figure 5-10 Plug assignment, RJ45	23
Figure 6-1 Removing the weather protection roof (similar illustration).....	24
Figure 6-2 Opening the ExCam IPP1488 (similar illustration).....	25
Figure 7-1 Axis IP Utility	29

History of revisions

Product: ExCam® IPP1488
 Title: User Manual for ExCam® IPP1488
 Doc. -Id. 260430-PT08BA-SHe-ExCam IPP1488_en_rev.01.docx
 Author: Sabine Heinz
 Created on: 04.05.2026

Rev. Index	Date	Name	Comment	Approved by the ATEX Supervisor
0	04.05.2026	S.Heinz	Compilation of the document	
1	18.06.2026	S.Heinz	Changes to the standard: pan-head screws	

1 Introduction

The ExCam IPP1488 is a cost-effective megapixel network camera for use in hazardous areas. The camera offers **8 MP resolution (3840 x 2160)**, a **powerful remote varifocus lens** and a **Deep Learning Processing Unit (DLPU)**. It is approved according to Directive 2014/34/EU (ATEX), IECEx, INMETRO and EAC-Ex and more.

The explosion-proof housing is approved for ATEX group II for zones 1, 2 as well as 21 and 22 including explosion groups IIC / IIIC. For further approvals, please check our product page <https://www.samcon.eu/en/products/network/excam-ipp1488>



During the development of the ExCam IPP1488, great importance was placed to safety, mechanical precision and high-quality stainless steel.

2 Technical data

2.1 Explosion protection

Identification marks

acc. to Directive 2014/34/EU:

 II 2G (zone 1 and 2)
 II 2D (zone 21 and 22)
 I M2 ¹

Explosion protection (gas):

Ex db IIC T5 Gb

Explosion protection (dust):

Ex tb IIIC T95°C Db

Explosion protection (mining):

Ex db I Mb

Protection flap ExCam:

IP 68 (IEC /EN 60529)

Transport/storage temperature:

-40°C...+65°C (non-condensing)

Ambient temperature (EX):

-40°C...+60°C (Type...L.H)

-60°C...+60°C (Type...LL.H)

Named testing laboratory:

TÜV Rheinland (number 0035)

EU type approval certificate:

TÜV 18 ATEX 8218X (2018)

IECEX Certificate of Conformity:

TUR 18.0023X (2018)

EAC-Ex TUR Report:

TC RU C-DE.HA65.B.01652/22

UK Ex

TÜV 22 UKEX 7137 X

IECEX Certificate of Conformity:

TUR 22.0076X (2022)

Other certificates see:

<https://www.samcon.eu/en/products/network/excam-ipp1488>

¹ Mining approval only for variants with armoured cable and plug termination or via flipConnect®.



Attention!
The instructions stated on the type plates have to be observed!

2.2 Illustration of the model key

Ex product-name	Model variants					Article no.
1)	2) Type	3) Housing- combination	4) Temp.- range	5) Cable length [m]	6) Cable termin.	Link to digital type plate
ExCam IPP1488	T08-	VA2.2.K4.BOR3-	L.H-	005.N-	P	22070651
	T08-	VA2.2.K4.BOR3-	L.H-	005.N-	T	22070652
	T08-	VA2.2.K4.BOR3-	L.H	005.A-	P	22070653
	T08-	VA2.2.K4.BOR3-	L.H	005.A-	T	22070654
	T08-	VA2.2.K4.BOR3-	L.H-	000.X-	X	22070650
	T08-	VA2.2.K4.BOR3-	LL.H-	005.N-	P	22070646
	T08-	VA2.2.K4.BOR3-	LL.H-	005.N-	T	22070647
	T08-	VA2.2.K4.BOR3-	LL.H	005.A-	P	22070648
	T08-	VA2.2.K4.BOR3-	LL.H	005.A-	T	22070649
	T08-	VA2.2.K4.BOR3-	LL.H-	000.X-	X	22070645

Table 2-1 Model key

Explanations:

- 1) **ExCam IPP1488** Functional camera description of the ExCam Series (technical data/
specification of the individual camera module)
- 2) **T08 =** SAMCON Production- Type 08
- 3) **VA2.X.K1.BOR =** T07 ex d housing (stainless steel 1.4404) with large diameter
 $\varnothing_{VA2}=113\text{mm}$
VA2.2.K1.BOR = T07 VA2.2 housing with medium body length ($L_R = 261\text{mm}$)
VA2.2.K4.BORX= K4 flipConnect® flange
VA2.2.KX.BOR3= Borosilicate sight glass DIN7080 (standard, for video cameras within visible
spectral range: $\lambda = 350\dots2000$ [nm] and photografical infrared range (NIR),
not suitable for thermographic applications (MIR/ FIR)
- 4) **L.H=** High temperature ($T_{amb} < +60^\circ\text{C}$)
L.H= Low temperatures ($T_{amb} \geq -40^\circ\text{C}$)
LL.H= PTC heater installed ($T_{amb} \geq -60^\circ\text{C}$)
- 5) **005.X =** Length of the connection line in meter at delivery; 5m is the
standard cable length, max. cable length is: 005...100 [m]
005.N = Non-armoured cable
005.A = Armoured cable
000.X = Without connection cable

- 6) **P** = Plug- termination (standard)
CAT6, RJ-45 network plug (heavy duty), AWG 26-22,
contact assignment acc. To specification EIA/TIA-568B
- T** = Terminal Box termination (optional)
4 x PoE Mode A connection (camera PoE) (see electrical connection)
- X** = Electrical connection via flipConnect®

2.3 Electrical parameters of the camera

Power supply of the camera without heating:

Voltage supply:	PoE, IEEE 802.3af/802.3at, class 3
Typical power consumption:	8.0 W
Maximum power consumption:	12.95 W

Power supply of the camera with heating:

Voltage supply:	PoE++, IEEE 802.3bt, class 7
Typical power consumption:	45.0 W
Maximum power consumption:	60.0 W

2.4 Cables and glands

2.4.1 Connection cable for devices with flipConnect®

Devices equipped with flipConnect® are supplied without a cable tail or a cable gland, only with non-explosion-proof blanking plugs (nylon PA3200, red) for fitting a suitable explosion-proof cable kit.

Quicklink for suitable cables and cable glands:

<https://www.samcon.eu/fileadmin/documents/de/60-Montage%26Installation/flipConnect-Compatibility.pdf>

2.4.2 Connection cable Ex-d – Ex-e

Description: Data transfer and power supply of the camera module (compliant with DIN EN 60079-14)

System cable SKD02-T:

Outside diameter:	8.9 ± 0.3 mm
Bending radius:	8 x D _a when installed and 4 x D _a after relocation
Data line:	4 x 2 x AWG23/1 CAT.6
Properties:	PUR halogen-free, flame-retardant, UV-resistant, chemical resistance, shielded

Quick link:

https://www.samcon.eu/fileadmin/documents/en/60-Assembling%26mounting/SKD02-T_Datasheet.pdf

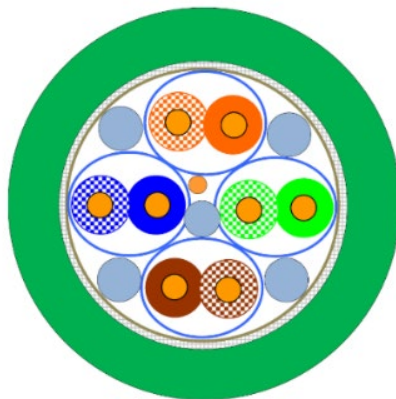

Figure 2-1 Sectional view of SKD02-T

System cable ASKD02-T (for mining):

Outside diameter:	12.0 ± 0.4 mm
Bending radius:	20 x D _a when installed and 10 x D _a after relocation
Data line:	4 x 2 x AWG23/1 CAT.6
Properties:	PUR halogen-free, flame-retardant, UV-resistant, chemical resistance, shielded (see www.samcon.eu)

Quicklink:

https://www.samcon.eu/fileadmin/documents/en/60-Assembling%26mounting/ASKD02-T_Datasheet.pdf

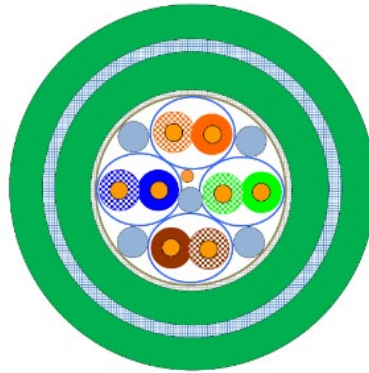

Figure 2-2 Sectional view of ASKD02-T

2.4.3 Cable glands PoE and protection hose

System cable SKD02-T → gland Capri ADE1F2 M20x1.5 Cap No.5 (7-12mm)

System cable ASKD02-T → gland Capri ADE4F Cap No.6

[Documentation ADE4F](#), [Declaration of Conformity](#), [Instruction Manual](#), [Datasheet](#)

2.5 Video-technical characteristics

We use the AXIS M1137 MkII Box Camera in a pressure-resistant enclosure. For details, please refer to the Product Documentation, video-technical data of AXIS®:

<https://www.axis.com/products/axis-m1137-mk-ii>



2.6 Other technical data

	Camera (Ex-d)	Terminal box (Ex-e)
Permissible ambient temperature	-40°C ... +60°C / -60°C ... +60°C (model key ...-LL.H-...)	-60°C ... +55°C
Protection class as per EN 60529/IEC 529	IP66/68 (Test conditions: 0.5h /8m and 24h/3m water column 5°C)	IP66
Housing material	stainless steel, mat. no. 1.4404	polyester resin
Weight	about 7 kg	about 1 kg
Dimensions	T07 VA2.2 D113mm x 261mm	145mm x 145mm x 71mm

Table 2-2 Other technical data

3 Safety Instructions



Please absolutely observe the installation instruction's safety directions of the T08 ExCam series!

Quick link:

<https://www.samcon.eu/fileadmin/documents/en/22-Ex-Network-Cameras/ExCam-Series-T08-EX-Installation-Manual-2020.pdf>

It is absolutely mandatory to adhere to the national safety regulations and regulations for prevention of accidents, as well as to the safety instructions given below in this User Manual!



Attention!

Cameras of type T08 ExCam are not suitable for use in zones 0 and 20. The ambient temperature, temperature class and explosion group written on the enclosure nameplate must be absolutely adhered to! The customer is not allowed to make any alterations of the devices! The devices must be operated in a proper and sound condition and only in the way intended.



Attention!

Repairs may only be carried out by using original parts from the manufacturer. Repairs which affect the explosion protection may only be carried out in accordance with the nationally applied regulations and exclusively by the manufacturer.



Attention!

Prior to installation, take external sources of heat or cold into account! The temperature ranges prescribed for storage, transport and operating must be adhered to!



Attention!

Adhere to the warnings given on the nameplate:

“WARNING – DO NOT OPEN IN HAZARD AREAS“

Note: Depending on the classification of hazard areas, a work approval must be obtained!



Using the devices in explosion-protected areas with regard to temperature and dust layers is defined in the respective national regulations.



The pre-installed RJ45 plug may only be connected in a safe area (non-Ex zone)!



Prior to the first use, you should test the camera corresponding to the instructions given in the chapter Commissioning.



Please observe the national safety regulations and regulations for prevention of accidents, as well as to the safety instructions given below in this User Manual!

4 Installation

For commissioning and operating the camera, the relevant national regulations, as well as the generally accepted rules of technology shall prevail. Before mounting the camera, thoroughly check it for any transport damage, especially on the housing and cable. Installation, electrical connection and the first start must only be carried out by qualified specialists.

Work preparation:



Attention!

Prepare your work carefully and in accordance with the relevant regulations.



Attention!

Depending on classification of hazard areas, it is imperative to obtain a work approval first!

When you open the pressure-resistant enclosure under voltage, it is absolutely necessary to prevent potentially explosive atmosphere!

To ensure the best image quality delivered by the network camera, plan the installation site carefully (consider light conditions, object distance or size, angle and minimum object distance to the focus).

- Use appropriate tools and aids.
- When working, ensure a safe stand.
- Make sure that any static charge is avoided.



Attention!

Please observe the national security, installation and accident prevention regulations (e.g. DIN EN 60079-14) and the safety instructions in this User Manual, as well as the ones in the Installation Guidelines!



Attention!

Adhere to the provisions of the IECEx, ATEX and EX installation instructions for mounting and starting up!



Attention!

Please pay attention to the national and local regulations for mounting heavy loads. In case of doubt, take appropriate security measures.



Attention!

Always mount the camera using the appropriate screw and hex nut (1 screw conforming to DIN 6921 M8-A4-70 or ISO 4017 M8-A4-70/ DIN 933 M8-A4-70 and hex nut DIN 4032 M8-A4-70) and the appropriate torque.

Alternatively: 4 pan-head screws ISO 7380-2 M6x8-A4-70-TX30.

Drawings for drill hole patterns and further information can be viewed on our product page:

Quick link:

<https://www.samcon.eu/en/products/network/excam-ipp1488>



Optional mounting accessories

Wall bracket WMB-...		WALL MOUNT BRACKET WMB-VA2.0-VA2.2 Wall bracket for devices of T08-VA2.0-VA2.2 series Suitable for hanging the camera on walls. Material: stainless steel 1.4404 Load bearing: 25 kg Dimensions: 80 x 100 x 275 mm
Weather protection roof WPR-...		WEATHER PROTECTION ROOF WPR-VA2.2 Weathershield for cameras of the T08-VA2.2-Series
Pole adapter PMB-...		WALL MOUNT BRACKET PMB Pole adapter for VA wall mount Material: stainless steel 1.4404 Suitable for pole diameters between 50 and 100 mm Load-bearing capacity: 50 kg Dimensions: 120 x 180 (x 130 bei Mast Ø 60 mm)

Table 4-1 Mounting accessories

5 Electrical connection



Attention!

The electrical connection of the equipment may only be carried out by qualified and skilled personnel!



Attention!

It is absolutely necessary to ground the ExCam® series' housing via the PA connection.



Attention!

Please observe the national security, installation and accident prevention regulations (e.g. DIN EN 60079-14) and the safety instructions in this User Manual, as well as the ones in the Installation Guidelines!



Attention!

If possible, carry out initial commissioning when the outside temperature is positive to prevent condensation in the housing.

The ExCam® IPP1488 is supplied either with flipConnect® or an electrical connection cable of the type SKD02-T/ASKD02-T. The maximum transmission range from camera to the next active network interface is 100 meters and can be individually specified by the client. The user is NOT authorised to do electrical connection procedures inside the pressure-resistant enclosure.

5.1 Potential equalization

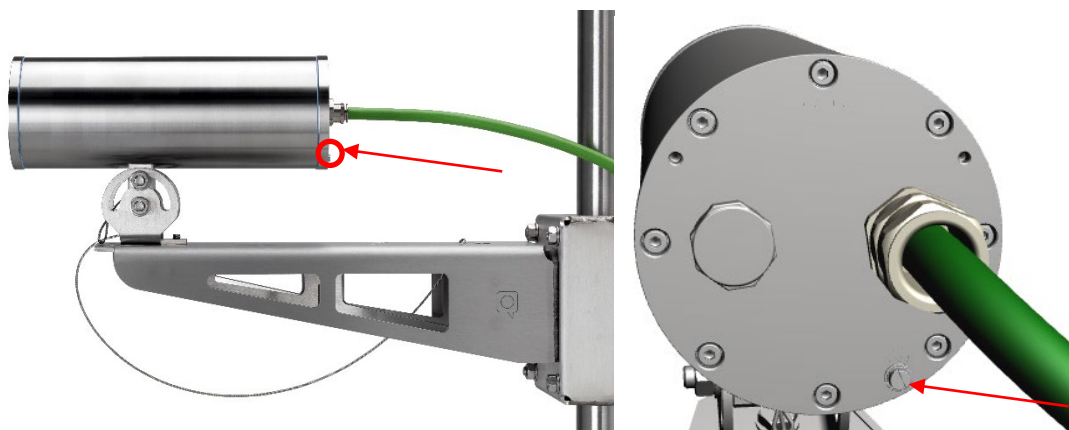

Figure 5-1 ExCam IPP1488 potential equalization (similar illustration)

Potential equalization/grounding of the camera housing is absolutely necessary, in order to avoid static charges and thus the formation of sparks. For this purpose, a screw terminal

is provided at the rear side, at the bottom (right) (see Figure 5-1). The cross-section of the potential equalization should comply with the National Ground Rules (at least 4mm²).

Wiring table:

Potential	Colour (IEC 60757)	Cross-section	Comment
PA	GN/YE	4 mm ² (rigid)	Terminal: Slotted screw M4x0.7 (DIN 84) with washer Ø9mm (DIN 125A), Keep 3 Nm tightening torque!

Table 5-1 Potential equalization

5.2 Connection work at the device and fuses

5.2.1 Connection work at the device via flipConnect®

We show the procedures of electrical connection via flipConnect® in the following video tutorial: "Plug & Play Cable Connection via flipConnect"

<https://go.samcon.eu/flipconnect>

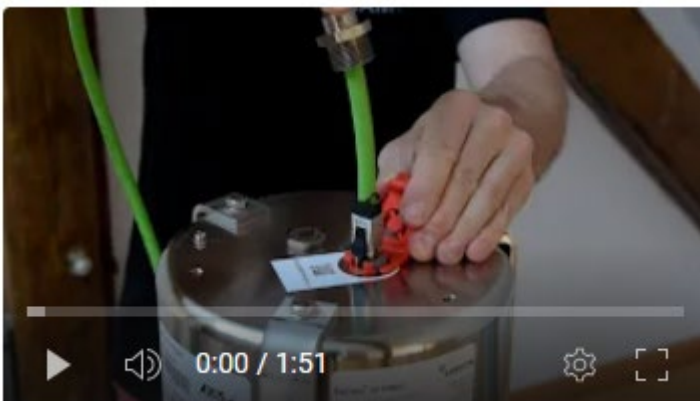
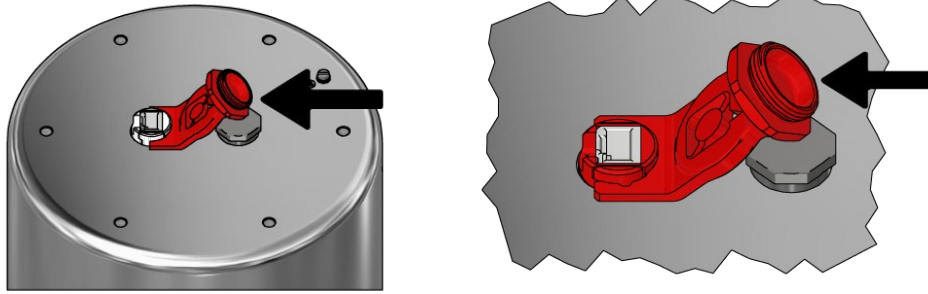

Figure 5-2 Connection via flipConnect®

Unscrew the red blind plug (with integrated auxiliary tool) from the housing and **keep it save**.



Fixate the RJ45 socket as shown in the figure below.



Choose a suitable cable and cable gland (e.g. the provided). Put the gland over the cable. Caution: the selected plug must be of the same length or shorter than the supplied one. Follow the respective instructions of the components.

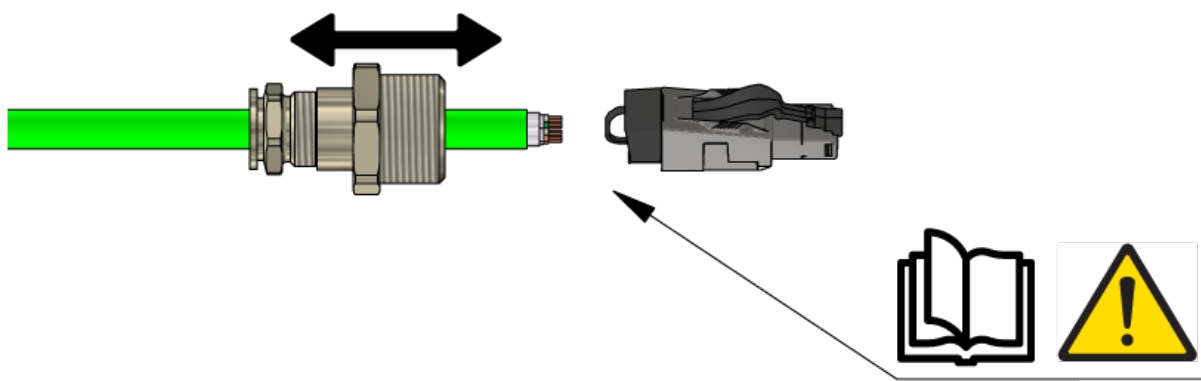

Plug in the RJ45 plug with the cable pigtail into the socket until the lock engages.

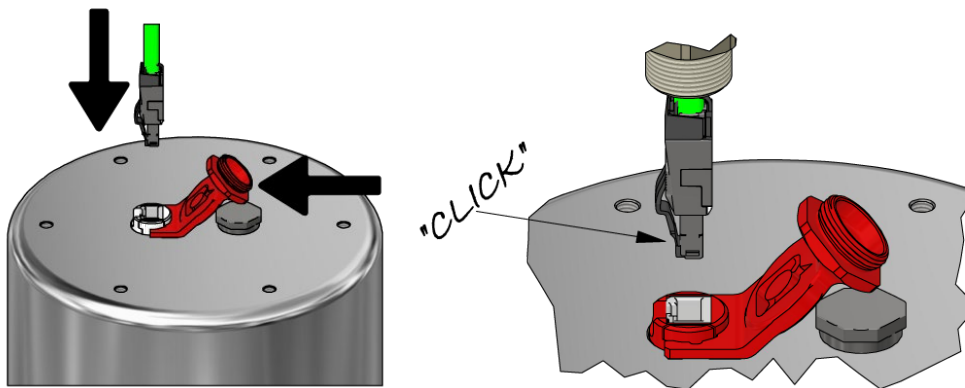

Remove the auxiliary tool and apply glue to the gland's inner thread. Then screw the gland into the housing. Attention, the cable is still movable and the gland's outer ring open.

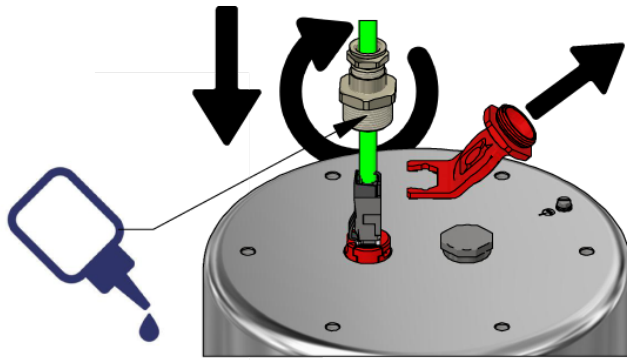

Push the cable down.

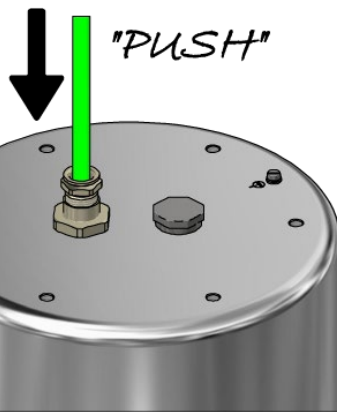

Fasten the cable gland's outer ring. Use Loctite and refer to the operating instructions of the selected gland in order to observe the appropriate fastening torques.

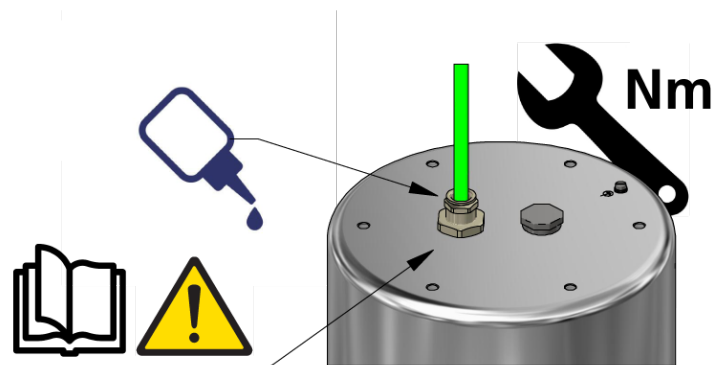

Done.



Attention!

Use appropriate RJ45 plug! Pay attention to shielding, cross-section and outer diameter of the cable!

5.2.2 Connection work at the device without flipConnect®

Cable gland (Capri ADE 1F2) for non-armoured cables
 SKD02-T - digital video stream
 Control system and power supply (PoE) of the camera module
 Cable gland (Capri ADE 4F) for armoured cables

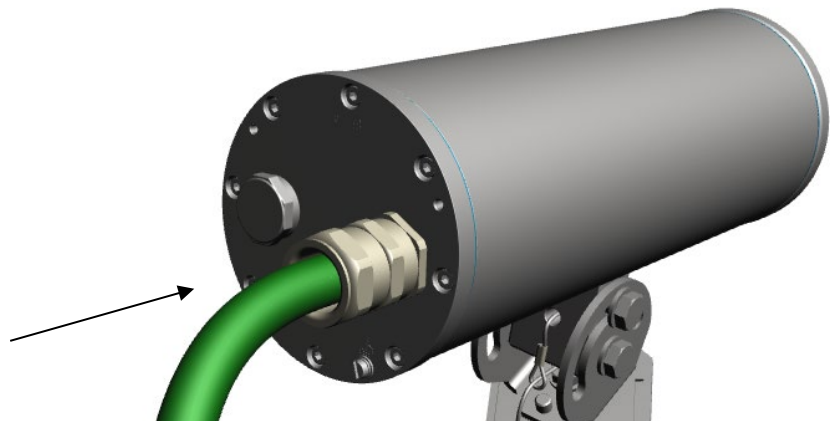

Figure 5-3 Cable gland (KLE) and supply line

The green system cable is intended for communication and data transfer to the connected network devices and, at the same time, for voltage supply (PoE) to the camera. To ensure the power supply of ExCam IPP1488 (*Powered Device/ PD*), it is necessary to make sure that the power-over-Ethernet provider fulfils the specification IEEE 802.3af/802.3at Class 3 (models without heater) or IEEE 802.3bt Class 7 (models with heater). Make sure there is sufficient power on the switch (power sourcing equipment) depending on the model variant used. The data transfer of the ExCam IPP1488 series is done via a 100 Mbit/s Ethernet connection (100BASE-TX).

The figures 5.4 and 5.5 illustrate the potential cable terminations of the ExCam IPP1488. Possible terminations are: terminal box or plug.

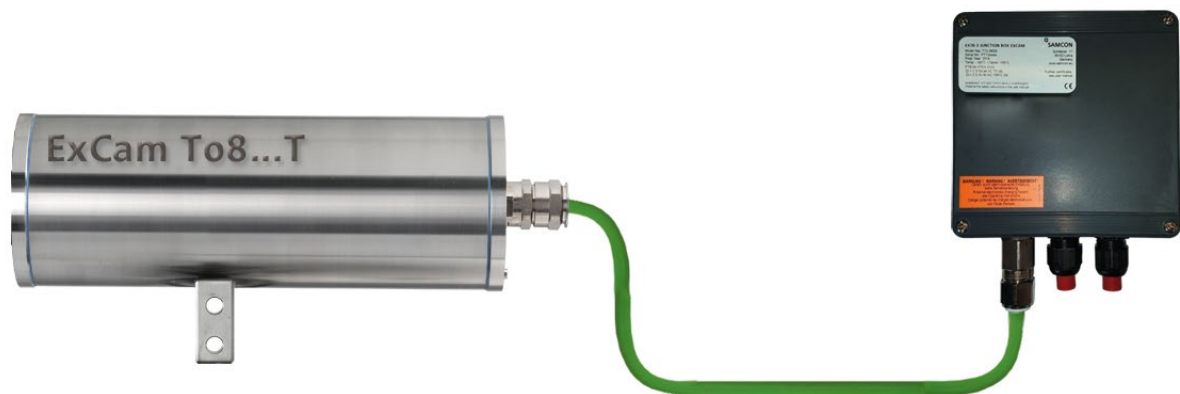

Figure 5-4 ExCam IPP1488 T08-VA2.1.KX.BOR-L.H-xxx.X-T (similar illustration)



Figure 5-5. ExCam IPP1488 T08-VA2.1.K1.BOR-L.H-005.X-P (similar illustration)



Attention!
Never open the Ex-e terminal box under voltage!



Attention!
Adhere to the international installation regulations for connection chambers with increased safety (Ex-e).



Attention!
Adhere to the separate Usual Manual for the Ex-e connection chamber attached in the annex.

Video Tutorial:

Please view our video tutorial:

“SAMCON 01 Wiring the cable SKDP03-T to the junction box ExTB-3”
<https://go.samcon.eu/v01>



Figure 5-6 Video Tutorial ExTB-3

The pin assignment of the SKD02-T is executed in accordance with the standard EIA/TIA-568B for 100BaseTX as follows:

Camera (Ex-d) (T568B)	Colour SKD02-T (IEC60757)	Terminal ExTB-2	Cross-sectional surface	Comment
Tx+	WH / OG	1	0.26 mm ²	Solid conductor
Tx-	OG	2	0.26 mm ²	Solid conductor
Rx+	WH / GN	3	0.26 mm ²	Solid conductor
Rx-	GN	4	0.26 mm ²	Solid conductor
(PoE +48 VDC)	WH / BU	5	0.26 mm ²	Solid conductor
(PoE +48 VDC)	BU	6	0.26 mm ²	Solid conductor
(PoE GND)	WH / BN	7	0.26 mm ²	Solid conductor
(PoE GND)	BN	8	0.26 mm ²	Solid conductor
GND/SHD	YE / GN	PE	2.5 mm ²	Flex

Tab. 5-2. Wire assignment of terminal box ExTB-2 (SKD02-T)

The pin assignment of the ASKD02-T is executed in accordance with the standard EIA/TIA-568B for 100BaseTX as follows:

Camera (Ex-d) (T568B)	Colour ASKD02-T (IEC60757)	Terminal ExTB-2	Cross-sectional surface	Comment
Reinforcement	YE / GN	PE	2.5 mm ²	Flex
Tx+	WH / OG	1	0.26 mm ²	Solid conductor
Tx-	OG	2	0.26 mm ²	Solid conductor
Rx+	WH / GN	3	0.26 mm ²	Solid conductor
Rx-	GN	4	0.26 mm ²	Solid conductor
(PoE +48 VDC)	WH / BU	5	0.26 mm ²	Solid conductor
(PoE +48 VDC)	BU	6	0.26 mm ²	Solid conductor
(PoE GND)	WH / BN	7	0.26 mm ²	Solid conductor
(PoE GND)	BN	8	0.26 mm ²	Solid conductor
GND/SHD	YE / GN	PE	2.5 mm ²	Flex

Tab. 5-3 Wire assignment of terminal box ExTB-2 (ASKD02-T)

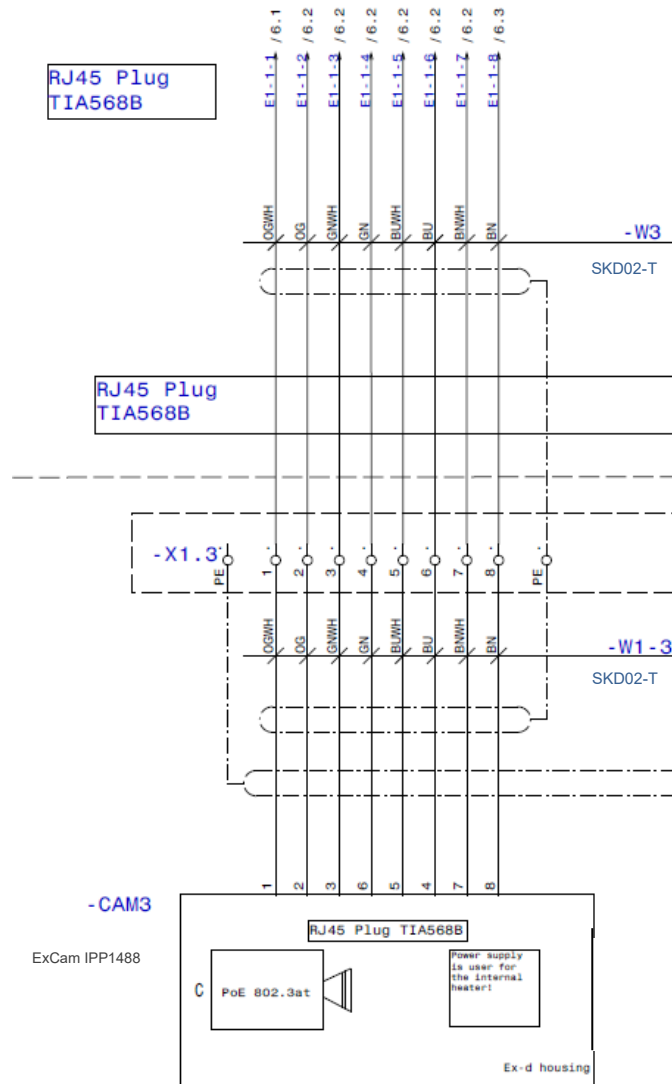

Figure 5-7 Sample circuit of terminal box ExtTB-2

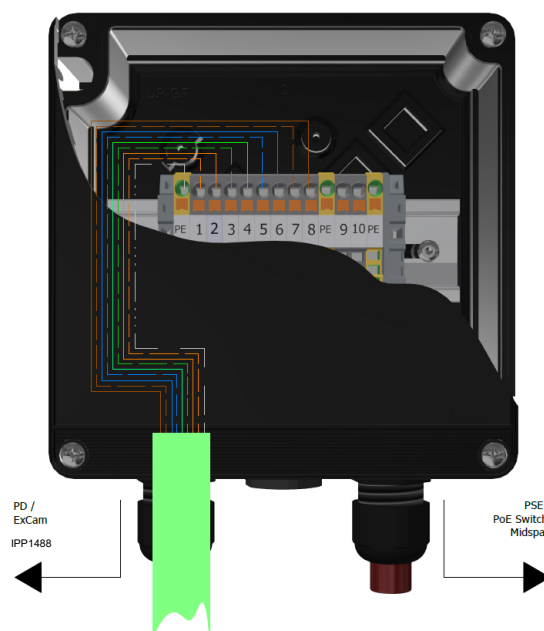

Figure 5-8 Photo of the wired terminal box ExtTB-2



Attention!

Introduce the foiling up to about 15 mm close to the terminals, in order to prevent alien crosstalk. Make sure that the foiling cannot cause any short circuit of the data pairs!



Attention!

Bring the twisted pair composite up to about 10 mm close to the terminals, in order to ensure interference immunity.



Attention!

Use only terminals approved by SAMCON.



Attention!

Finally, check your network installation with a Class-D Link Test.

5.2.3 Appropriate cables & cable entries

Devices equipped with flipConnect® are supplied without a cable tail or a cable gland, only with non-explosion-proof blanking plugs (nylon PA3200, red) for fitting a suitable explosion-proof cable kit.

Quicklink for suitable cables and cable glands:

<https://www.samcon.eu/fileadmin/documents/de/60-Montage%26Installation/flipConnect-Compatibility.pdf>

An essential component of system safety is the correct selection of cables, wires and cable entries.



Attention!

Cables and wires must comply with the requirements of the IEC 60079-0/1/7 & 14.



Attention!

The supply line must have a sufficient cross-section. The cable protection must comply with national and international regulations.

For non-binding configuration and planning guidelines, please visit our website:

Perhaps our video will help you:

"Cables for flameproof devices in potentially explosive atmospheres"

<http://go.samcon.eu/video-cable-ex>





Figure 5-9 Ex-d cable selection

Particularly for installations requiring a suitable barrier gland, make sure that you handle them correctly and observe the rules and notes given in the respective mounting and assembly instructions.

5.2.4 Plug assignments (RJ45)

The data transfer of the ExCam IPP1488 uses a 100 Mbit/s Ethernet connection (100BASE-TX).

If the cable termination uses a plug, the latter should be plugged into the RJ45 PoE slot of the network device (PSE). Prior to connecting it to the camera, the network device (PSE) can already be supplied with power, hence there is no „power ON“ priority which has to be observed.



Attention!

Use appropriate RJ45 plugs! Check the cable shielding, cross-section and the outside diameter!



Attention!

It is imperative to ensure a correct routing of the individual wires according to the EIA/TIA-568B"



Attention!

Finally, check your network installation with a Class-D Link Test.

Detailed instructions on how to connect a RJ45 plug are available in our video tutorial: “SAMCON 03 Mounting and installing the RJ45 jack to SAMCON cables”
<https://go.samcon.eu/v03>



Figure 5-10 Plug assignment, RJ45

5.2.5 Tests prior to switching on voltage



Attention!

Prior to starting the device, perform all tests as indicated by the national regulations. Furthermore, check the correct function and installation of the device in accordance with this User Manual and other applicable regulations.



Attention!

Incorrect installation or operation of the camera may lead to a loss of warranty!



Attention!

Do not switch on the camera at temperatures below 0°C!

6 Working inside the housings (Ex-d)

The customer may open the camera housing only if it is absolutely necessary. Only exchanging the SD memory card or a hardware reset are reasons for this.

6.1 Preparation for work:



Attention!

Prepare your work carefully and in accordance with the relevant regulations.



Attention!

Depending on classification of hazard areas, it is imperative to obtain a work approval first!

If you adjust the camera yourself or open the pressure-resistant enclosure (Ex-d) under voltage, it is absolutely imperative to prevent potentially explosive atmosphere!

6.2 Opening the camera housing

If the ExCam IPP1488 is equipped with a weather protection roof this has to be removed prior to starting your work! To do so, loosen the 4x button head screws M4 (see [Mounting Instruction WPR-VA2.2](#)) at the front and rear sides of the bracket holders (Figure 6-1).

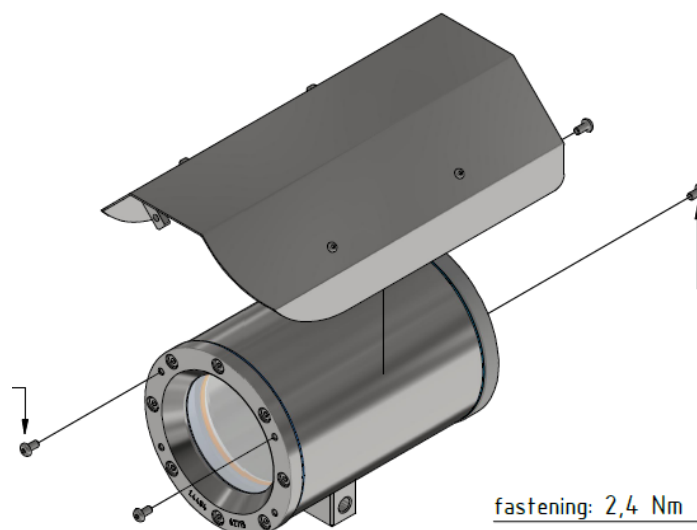

Figure 6-1 Removing the weather protection roof (similar illustration)

To open the stainless-steel housing (T07 VA2.X.x.x) of ExCam IPP1488, loosen the eight cylinder-head hexagon screws (DIN 912/ ISO 4762) together with their spring rings (DIN 127A) on the rear side of the cable and power supply flange (see Figure 6-2).

Caution: do not touch the screw threads with your skin or clothes! On the threads, there is LOCTITE® 243™ (chemical basis is dimethacrylate ester) applied to prevent the bolted connection from unintentional loosening because of impacts and vibrations and to seal them tightly. It is not permitted for the customer to open the front-side sight glass flange! There is no need of such an action.

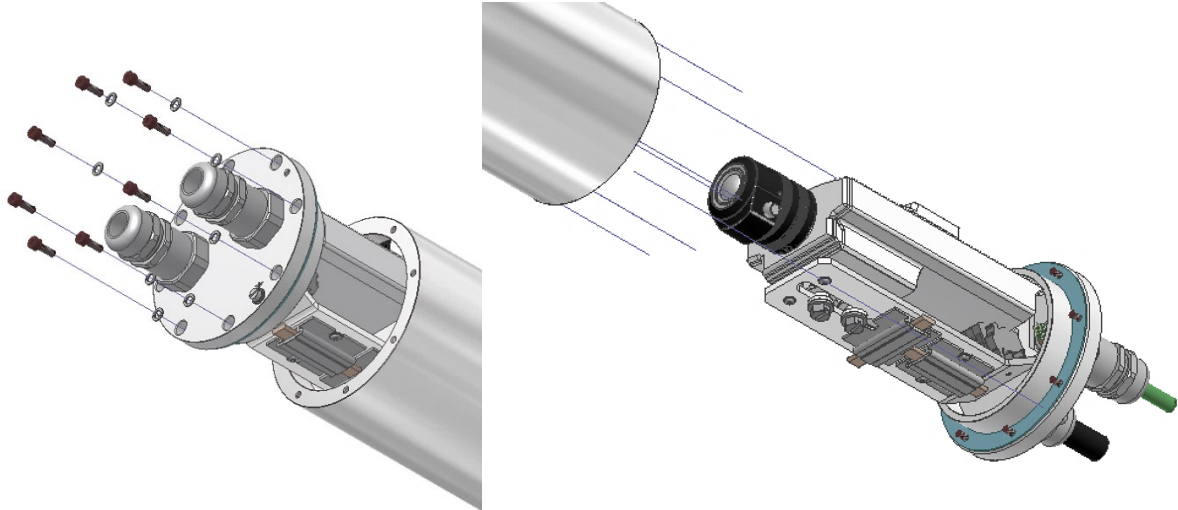

Figure 6-2 Opening the ExCam IPP1488 (similar illustration)

Carefully pull out the cable and supply flange to the rear, as straight as possible. Because of negative pressure, it may be difficult to remove the flange. The cylindrical clearance fit (H8f7 - DIN ISO 286) of the camera body and flange may not be tilted! Risk of damage to the flame-proof gap (DIN EN 60079-1:2012)!

Attention: The mounting adapter with the camera module and optics, as well as the temperature control, and (if applicable) auxiliary relays and terminal block are fixed on the cable and supply flange. Dealing with these components, too, you have to work very carefully and precisely in order to avoid canting and damage to the in-built components! Caution: do not touch the cylindrical fit surface with your skin or clothes! On the surface, there is oil lubricating paste to protect the surface against fretting corrosion and mechanical stresses.

When you open the housing, pay attention that you do not damage the GYLON® flat seal (blue, RAL5012) and do not make it dirty! The flat gasket is loosely attached to the cable and power supply flange. It is fixed only by the bolted connections!



Attention!

Pay attention not to damage the surface of the drill hole and the shaft (fitting) of the flame-proof gap.



Attention!

Pay attention not to damage the housing seals. Keep them clean!

6.3 Removing / inserting a SD memory card

Note:

The ExCam IPP1488 has a slot for a micro SDHC memory card (card not included). Saved video files can be played and deleted via the web interface. They are also available in a download list. Moreover, the videos available in the memory card can also be accessed via FTP server in the network.

If the memory card has to be replaced by the user, it should be, as far as possible, empty and pre-formatted with an ext4 or vFAT file system.



When touching electrical components, observe potential equalization (grounding of the body): carry electrostatic-discharge clothes, a PE wristband etc.!

6.4 Hardware Reset

To set all the parameters of the ExCam IPP1488 (including the IP address) to default values, you should run a hardware reset.

The parameters can be reset via the web interface or manually. If the camera placed in the network can no longer be reached or its state is uncontrollable, the reset should be performed manually. To do so, proceed as follows:

1. Disconnect the camera installation module (Axis P1488-LE) from the power supply.
2. Press and hold the control button (see the illustration below) and, at the same time, connect the system to the voltage supply (PoE).
3. Hold the control button pressed for about 30 seconds.
4. Release the control button. After about a minute, the AXIS P1488-LE will return to factory defaults. If there is a DHCP server in the network, the IP address will be the following: 192.168.0.90 (subnet masking 255.255.255.0).
5. IP address and password can be redefined. If the hardware reset is not satisfactory or the network camera shows serious conflicts or does not work as usual (errors in the browser visualisation, frozen images, control commands no longer processed, slowing down of the system, etc.), it may be necessary to re-install the current firmware, or to install an update (see Chapter 7).

6.5 Closing of the pressure-resistant housing

For closing the housing, proceed in reverse order as when opening. Use exclusively original screws included in the supply.

The cable and power-supply flange is fixed by 8 cylinder-head screws M4*0.7 (ISO metric right-turning) with 12 mm thread length (DIN 912/ ISO 4762, grade 6g). Materials of bolted connections are identical to the pressure-resistant stainless steel housing (standard material no. 1.4404 AISI316L). Check whether the threaded holes are undamaged and clean. Before closing, it is also absolutely imperative to check the flame-proof gap (circular cylindrical fit).



Attention!

If any mechanical damages occurred to the fitting gap, it is no longer allowed to use the housing!



Attention!

Do not lock-in any foreign objects in the housing.



ATTENTION!

Insert the flange to reach the end position, in order to ensure ignition protection and the protection level (IP) of the housing.

Dismantled screw locks (spring washers DIN 127A) must be used again.

The GYLON® gasket must be used in undamaged condition, according to the flange hole pattern, and placed between the flange and the hull. The lateral position of the flat surface / contact surface is arbitrary. If, when closing the housing, you see that the surface of the fitting gap is dirty or insufficiently lubricated, clean it with a clean cloth and de-grease it with a suitable cleaning agent. Then re-grease it with lubricant suitable for this specific application (e.g., Molykote® P-40 gel for standard applications or special grease OKS 403 in the event of heavy seawater influence).

The screwed connections of flange and body components must always be tightened *crosswise* to a torque of **3 Nm!** Do not tighten the screw too strongly! It can cause rupture of the cylinder head or over-stretching the threads, and thus to impairment of the pressure resistance or ignition protection class.



Cylinder-head bolts for explosion-proof connection of the camera body with the flange component must always be tightened at a 3 Nm torque - crosswise and evenly! Use Loctite.

7 Network access and visualization

The most important procedures of the first starting up the camera are described below. The configuration menu of the web surface allows an intuitive navigation and offers several configuration possibilities. For detailed documentation and information how to use the web Interface, please see the User Manual for Axis or visit the following website:

<https://help.axis.com/axis-p1488-le>

The delivered ExCam IPP1488 is set to the applicable net frequency (50Hz or 60Hz). If the camera is used at a location with a differing net frequency, the image might start to flicker, particularly in surroundings with fluorescent tubes. In such a case, the applicable settings have to be carried out inside the menu “System Options>Advanced>Plain Config”.

User: root
Password: root

7.1 Browser Support

A list of the currently supported web browsers, operating systems, required add-ons, etc. can be viewed at:

<https://help.axis.com/access-your-device>

<https://www.axis.com/support>

7.2 Assigning the IP address

The ExCam IPP1488 is intended for use in an Ethernet network and requires an IP address to access and control it. In the most today's networks, a DHCP server is integrated. This server automatically assigns an IP address.

If there is no DHCP server available in the network, the IP default address of ExCam IPP1488 is “**192.168.0.90**” (subnet masking **255.255.255.0**).

With the “AXIS IP Utility”, it is possible to determine the IP address under Windows; the included USB stick contains this application.

<https://www.axis.com/support/tools/axis-ip-utility>



If it is not possible to assign the IP address, it might be necessary to change the firewall settings!

The "AXIS IP Utility" tool automatically recognizes all ExCam devices and visualises them in the device list. It can also be used to manually assign a static IP address. For this purpose, the ExCam IPP1488 network camera has to be installed in the same physical network segment (physical subnet) as the computer on which the AXIS IP Utility is running. The network signature of ExCam IPP1488 is "AXIS P1488-LE" (see Figure 7-1). MAC address and serial number for clear device identification are also detected and displayed.

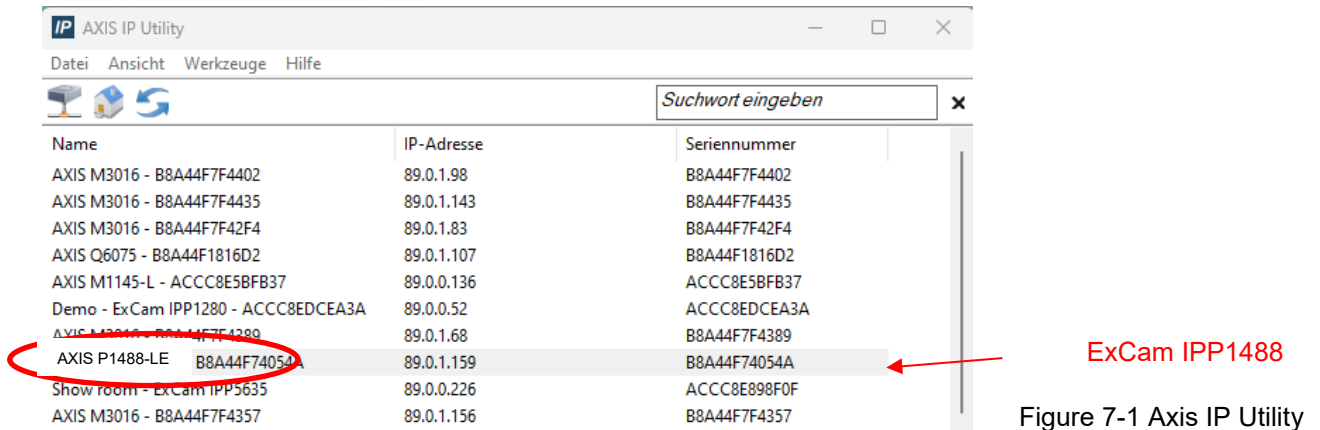

ExCam IPP1488
 Figure 7-1 Axis IP Utility

7.3 Password/ Identification

The following user name is set at the factory: **root**
 The following password is set at the factory: **root**

8 Maintenance / Modification

The applicable regulations for the maintenance and servicing of electrical devices in potentially explosive atmospheres must be adhered to.

The required maintenance intervals are specific to the individual devices. The operating company has to determine these intervals depending on the application parameters. The maintenance tasks especially include examination of parts on which the ignition protection depends (e.g., proper condition of the casing, seals and cable entry points). If maintenance measures are necessary they have to be initiated and/or executed.

8.1 Repair and correction

Repairs may only be carried out with original parts of SAMCON Prozessleittechnik GmbH. Damaged pressure-resistant housings have to be replaced completely. In case of doubt, send the part in question back to SAMCON Prozessleittechnik GmbH.

Reparations concerning the explosion protection must only be carried out in accordance with nationally applied regulations by SAMCON Prozessleittechnik GmbH or by an authorised electrical technician authorised by SAMCON Prozessleittechnik GmbH. Rebuilding of or alterations to the devices are not permitted.

9 Disposal / Recycling

When disposing of the device, nationally applicable regulations must be observed.

This Document is subject to alterations and additions.

10 Drawings, 3D models, certificates and further documentation

All drawings, 3D models, certificates and other information are available in the download area of the product page on our website:

<https://www.samcon.eu/en/products/network/excam-ipp1488>

Ex Cameras

Fix Bullet Cameras

Varifocal Bullet Cameras

ExCam miniTube IP

ExCam IPM1137

ExCam IPM1137-LE

ExCam IPP1387

ExCam IPQ1656 (DLPU)

ExCam IPP1488

Autofocus/Motorzoom Bullet Cameras

Panoramic Cameras

PTZ Dome Cameras

Thermal Cameras

Modular Ex Cameras

Analog Ex Cameras (AHD)

Robust Cameras (non-ex)

Your Individual Camera (BTO)

Ex Luminaires

Robust Luminaires

Ex-d Camera Enclosures

Connection Systems

Cables for Ex-Areas

Mounting Systems

Wash and Wipe Equipment

Software

Downloads:

- [Comparison Chart](#)
- [Datasheet](#)
- [Usermanual](#)
- [Drawing](#)
- [CAD-Files \(DXF\)](#)
- [3D-Model VA2.2 \(pdf\)](#)
- [3D-Model VA2.2 \(stp\)](#)
- [Ex Installation Manual](#)
- [ATEX Type Examination](#)
- [IECEX Cert.-of-Conformity](#)
- [INMETRO](#)
- [EAC-Ex-Certification](#)
- [MASC \(Southafrica\)](#)
- [UKEX-Certification](#)
- [Dec. of Conformity](#)

ExCam[®] IPP1488

8 MP resolution meets a powerful vario focus lens and DLPU

The ExCam IPP1488 is a cost effective megapixel network camera, particularly suitable for use in hazardous areas. Besides **8 MP resolution (3840 x 2160)** it offers a **powerful vario focus lens** and a **Deep Learning Processing Unit (DLPU)**. It is approved according to Directive 2014/34/EU (ATEX), IECEx and EAC-Ex. These and other available approvals can be found in the download area.

Features

- Broad Certification Landscape for Hazardous Areas (ATEX, IECEx & more)
- Single-Cable-Solution (PoE / 24VDC)
- Protection Level of IP66/68 (IEC 60529)
- High Resolution: 3840x2160 (8 MP bei 25/30 fps)
- Powerful Vario-Focus Lens
- Lightfinder 2.0 and WDR Technologies
- Object Analytics thanks to Deep Learning Processing Unit (DLPU)
- AV1 - Codec
- [Extensive Accessories](#)

Explosion-proof IP camera with ATEX, IECEx and EAC-Ex approval

The ExCam series is certified within the framework of the European (ATEX) as well as the international directive (IECEx). The explosion-proof housing is approved for ATEX group II for zones 1, 2, 21 and 22 including explosion groups IIC / IIIC. Furthermore, it now also has the EAC-Ex approval. During the development of the ExCam IPP1488, great importance was attached to safety, mechanical precision and high-quality stainless steel. In addition, a modular structure was at the forefront of the development. With regard to the technical characteristics, we have gone to the limits of what is feasible: In areas such as media resistance and ambient temperature, we are setting standards with the ExCam series.

Outstanding images as a basis for reliable analysis

A high image quality is of crucial importance in order to clearly capture a process and to be able to clearly identify the persons or objects involved. The highest image quality is the prerequisite for reliable analysis. Thanks to its resolution of 2160 p at 60 frames per second and thanks to Lightfinder 2.0 and WDR, the ExCam IPP1488 provides a reliable basis for powerful analysis functions .

Vario-focus

The ExCam IPP1488 offers a powerful vario-focus lens.

Lightfinder 2.0 and Forensic WDR

Lightfinder 2.0 and WDR are responsible for good image quality despite weak light. Lightfinder 2.0 ensures realistic and saturated colors even of moving objects even in low light. Forensic WDR compensates for differences in brightness in a scene, i.e. sharp images despite a high-contrast scene.

Artificial intelligence and camera? Clear!

Cameras have long ceased to be used for purely imaging surveillance. Due to the constantly improving processors and the associated performance of the cameras, the decentralized task of image evaluation can now also be carried out directly on the camera - so-called on-edge solutions. The advantage of this camera-based evaluation is above all a lower bandwidth usage, since the actual analysis is carried out from the raw data on the camera and only metadata has to be passed on. This means

If you wish additional technical information, please contact us at support@samcon.eu



SAMCON

Schillerstrasse 17, 35102 Lohra-Altenvers,
Germany
www.samcon.eu, info@samcon.eu
Phone: +49 6426 9231-0, fax: - 31

