

ExCam[®] SUFA4115



Datasheet.

Ultra compact ATEX, IECEx & EAC-Ex certified sensor unit with vario-focus *

Features.

- ✓ Certification for Hazardous Areas
- ✓ Ultra-Compact and Lightweight
- ✓ Single-Cable-Solution
- ✓ Protection Level of IP68 (IEC 60529)
- ✓ High Resolution: 1920x1080 (HDTV1080p)
- ✓ Varifocal-Lens
- ✓ Forensic-WDR Technology
- ✓ Compatible with FA54 Main Unit & ExCR FA54



Zones.

Group II (Gas & Dust)	ATEX / IECEx				
Zone	0	1	2	21	22
For use in	✗	✓	✓	✓	✓

More certificates upon request

Models.

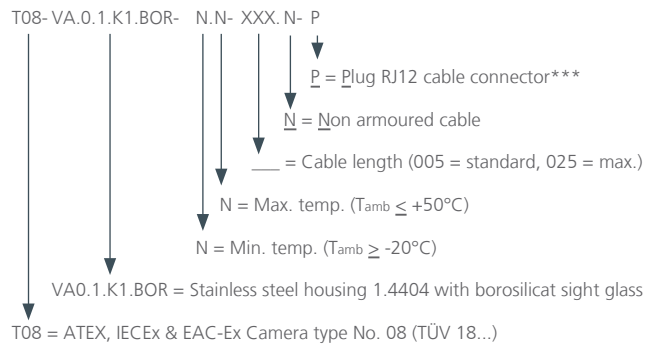

Dimensions.

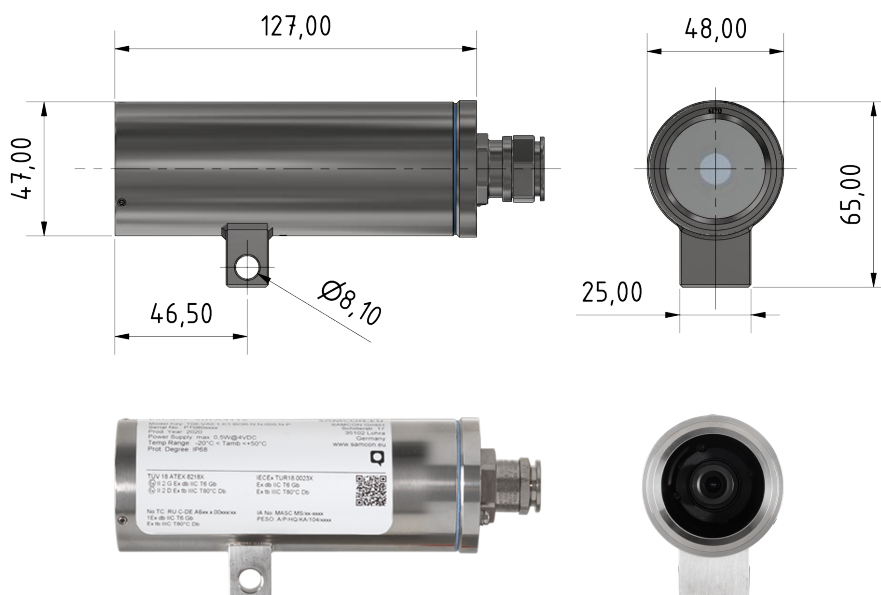

Data.

ExCam® SUFA4115



Explosion protection
Declaration of conformity:

DIN EN/IEC/GOST ... 60079-0,
DIN EN/IEC/GOST ... 60079-1, DIN EN/IEC/GOST ... 60079-31
TUEV-18-ATEX-8218X, IECEx-TUR-18.0023X,
No. TC RU C-DE.HA65.B.01652/22, TUEV-22-UKEX-7137X



Ex- Certificates:



Ex- Marking:
Explosion protection (gas):
Explosion protection (dust):

II 2G Ex db IIC T6 Gb
 II 2D Ex tb IIIC T80°C Db



Mechanical characteristics:

Sensor Unit:
Protection level:
Weight:

Stainless Steel (AISI 316L/1.4404)
IP68 (IEC/EN 60529)
0.7 kg



Range of temperature:

-20°C to +50°C



Power supply:

ExConnection Rail FA54 or FA54 Main Unit
max. 1,2W@4VDC



Connection cable type:
Outside diameter:

WWW.SAMCON.EU/SKD04-T.flex ... Cat.6 / 4x2xAWG24/7 ...
8.7 mm***



Lens

Type:
Field of view:
Minimum illumination:
Wide Dynamic Range:

Fixed iris, varifocal, 2.8 mm bis 6.0 mm, F2.0
HfFoV: 82° – 53°
0.2 lux
Forensic WDR



Camera

Image sensor:
Shutter time:

1/3" (effective) progressive scan RGB CMOS
1/32500 to 1/25 s with 50Hz
1/32500 to 1/30 s with 60Hz
1920x1080 HDTV 1080p
25/30 fps (50/60 Hz)

Resolution:
Frame rate:

***Required hardware:**

ExConnection RailFA54 or FA54 Main Unit

Optional accessories:

Wall mount bracket (WMB), Pole mount bracket (PMB), Hinge attachment (SCH)

Schillerstrasse 17
D-35102 Lohra-Altenvers

info@samcon.eu
T: +49 6426 9231-0
F: +49 6426 9231-31

Connection Options.



Up to 4 x ExCam SUFA4115



AXIS FA54 MAIN UNIT



Ethernet



Up to 4 x ExCam SUFA4115



ExConnection Rail FA54



Ethernet



* = Only works in connection with a suitable Main Unit

** = Illustrations show models with accessories that are subjected to an extra charge

*** = Cable is not longitudinal tight (see UM); Please observe the requirements of DIN/EN/IEC 60079-14.