

Wall Mount Bracket WMB-VA2.3

Datasheet.

Features.

Compatible

with all cameras of the ExCam Series with the model-key T08-VA2.3.

For easy mounting on wall or ceiling.

Data.

Range

Manual pan angle: 360°

Manual tilt angle: 90°

Mechanical Characteristics

Material: Stainless steel AISI 316L/1.4404

Weight: 6.0 kg

Point load: 50 kg

Dimensions WxHxD [mm]: 140x185x445

Scope of Delivery

includes hinge attachment and mounting material

-Hinge attachment VA2.3

-1 screw M10x12

-2 screws M10x70

-3 nuts M10

-6 washers M10

-1 washer M8

-1 screw M8x16



Dimensions [mm].

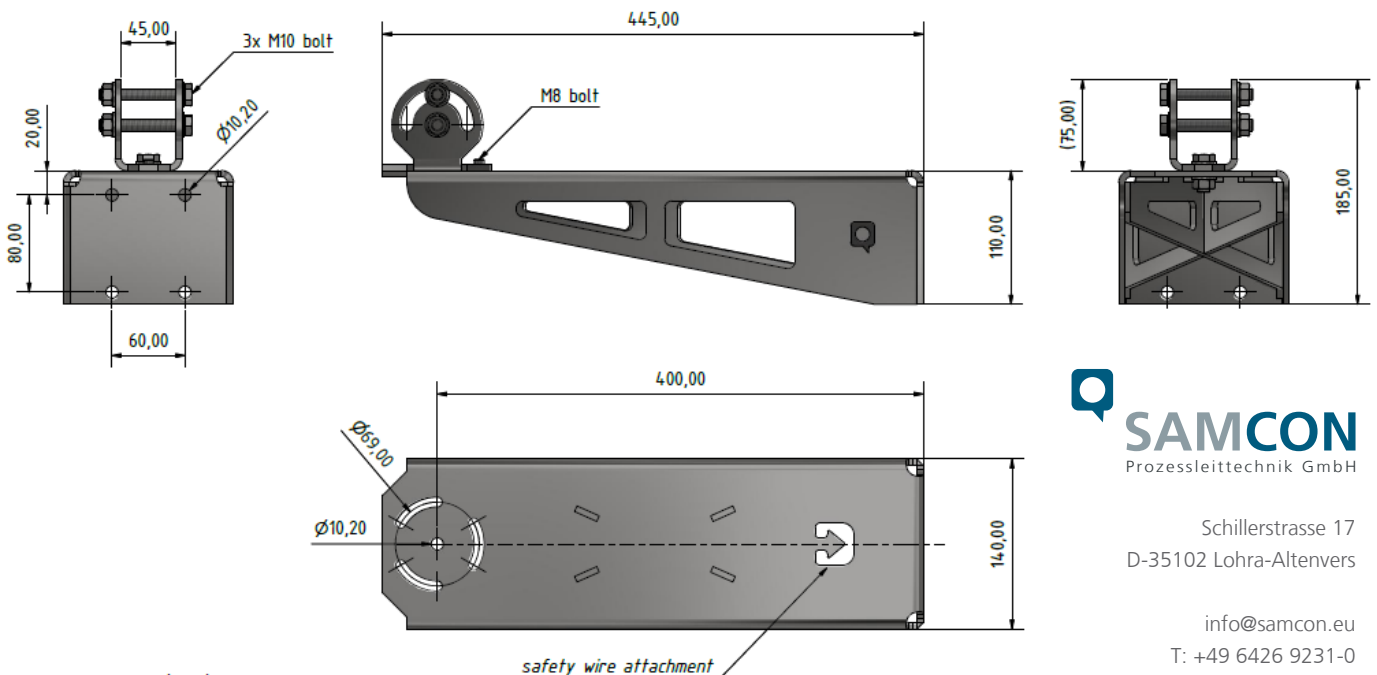

 **SAMCON**
Prozessleittechnik GmbH

Schillerstrasse 17
D-35102 Lohra-Altenvers

info@samcon.eu
T: +49 6426 9231-0
F: +49 6426 9231-31

© SAMCON GmbH All rights and technical changes reserved. No liability for wrong or missing data.